

CAM timer data - Schaltzeiten

Cam	Start	End	Notes
Cam 1	14	12	
Cam 2	24	22	
Cam 3	34	32	
Cam 4	44	42	Adjustable

Time in seconds / Zeit in Sekunden: 0:00, 0:03, 0:05, 2:43, 3:00

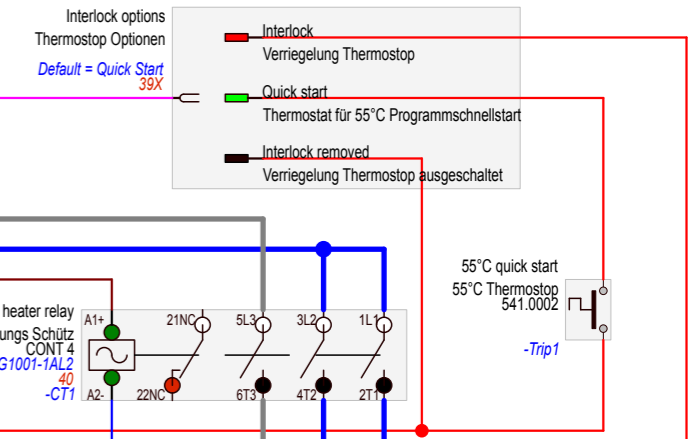
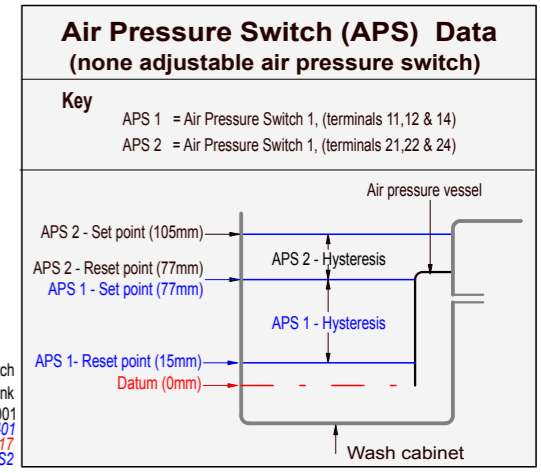

DCN No.	Revision	Comment	Name	Date
DCN0163	G	Machine full relay added	MRD	24/09/12
DCN0149	H	Changes for CB approval	MRD	11/02/13
DCI-0183	I	Aligned dwg to harness	TLC	04/12/2013



Any information or descriptive matter set out hereon are the confidential copyright property of CLASSEQ and must not be disclosed, loaned copied or used for manufacturing, tendering or any other purpose without written permission from Classeq

Diese Zeichnung und jeglicher weiterer Inhalt aus diesem Dokument sind vertraulich und Eigentum von CLASSEQ. Ohne die Erlaubnis von CLASSEQ dürfen die Inhalte nicht kopiert oder anderweitig genutzt werden

Special Notes

Eco 3, Hydro 750, Duo 3, Duo 750

Standards

CE & CB scheme

Title	P2 - Standard 32 amp wiring harness Standard 32 A Kabelbaum	Drawn	M Downing
Loom / Dwg No.	LM-P2-30A	Approved	
		Date	07.07.08
		Sheet	1 of 1